



**MON
SEC**

Typ D

www.monsec.ch

MON SEC

Typ D

Standard visualization

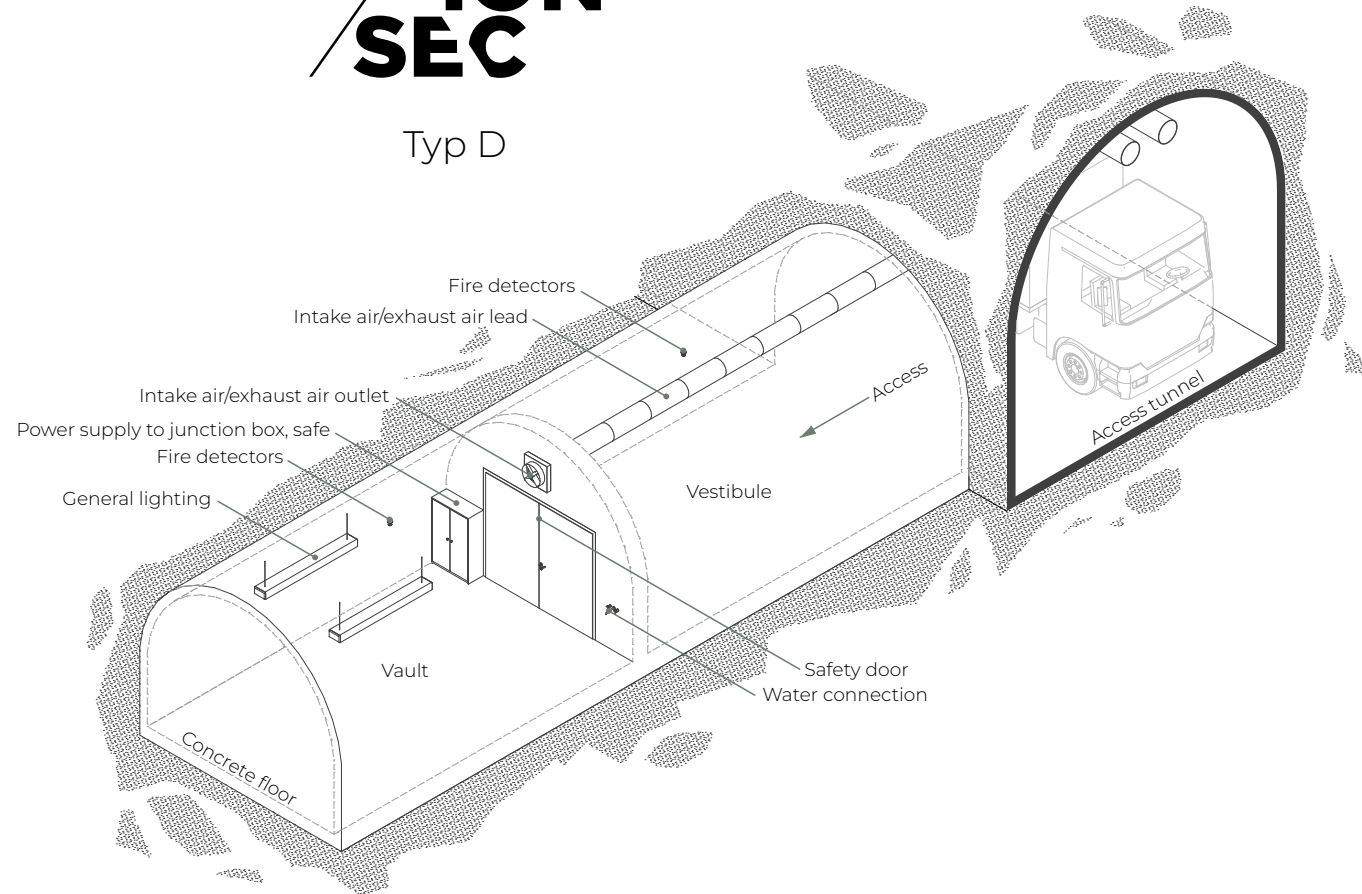

Vault

Description	Length	Width	Surface area	Height	Volume	Base price in CHF* excluding value added tax
Typ A	5 m	5 m	25 m ²	4 m	100 m ³	530'000
Typ B	10 m	5 m	50 m ²	4 m	200 m ³	690'000
Typ C	20 m	5 m	100 m ²	4 m	400 m ³	940'000
Typ D	20 m	8 m	160 m ²	8 m	1'100 m ³	1'350'000

*Custom modifications are not included in the basic price.

MON SEC

Typ D

Plot

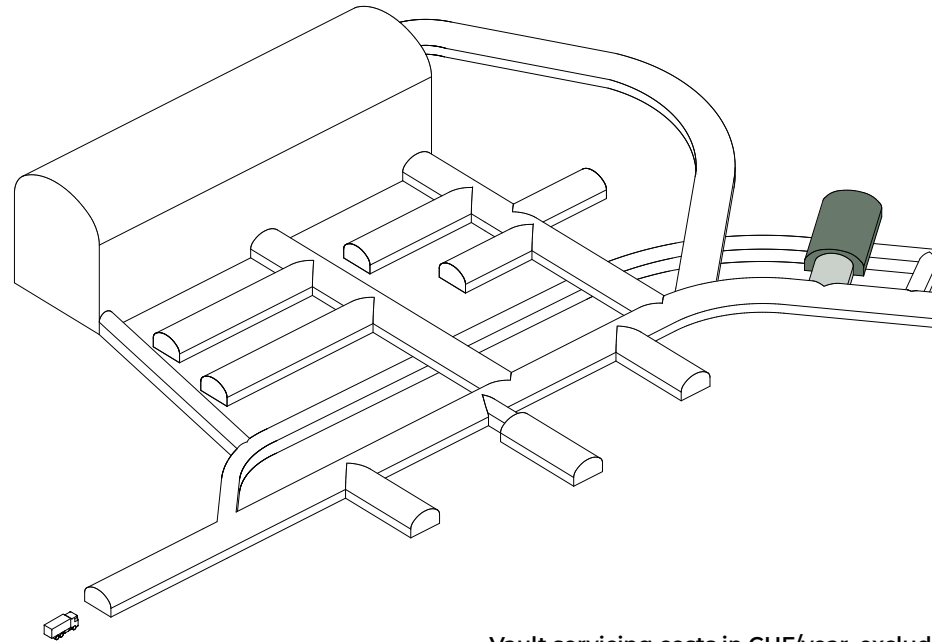

Vault

Vault servicing costs in CHF/year, excluding value added tax

Description	Unit	Area of plot	Proportional value	Operating costs	Renovation fund	Profit	Service costs TOTAL*
Typ A	1	ca. 250 m ²	100	21'600	3'300	4'800	29'700
Typ B	1	ca. 300 m ²	105	22'680	3'465	6'400	32'545
Typ C	1	ca. 350 m ²	115	24'840	3'795	9'200	37'835
Typ D	1	ca. 400 m ²	120	25'920	3'960	9'600	39'480

All figures are approximate.

* Excluding building lease charge per year as defined in the lease contract.

MON SEC

Typ D

Cross-section

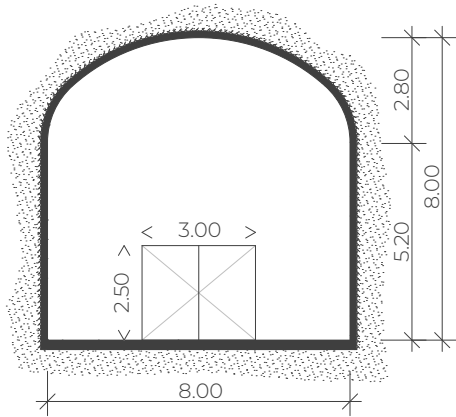

Longitudinal section

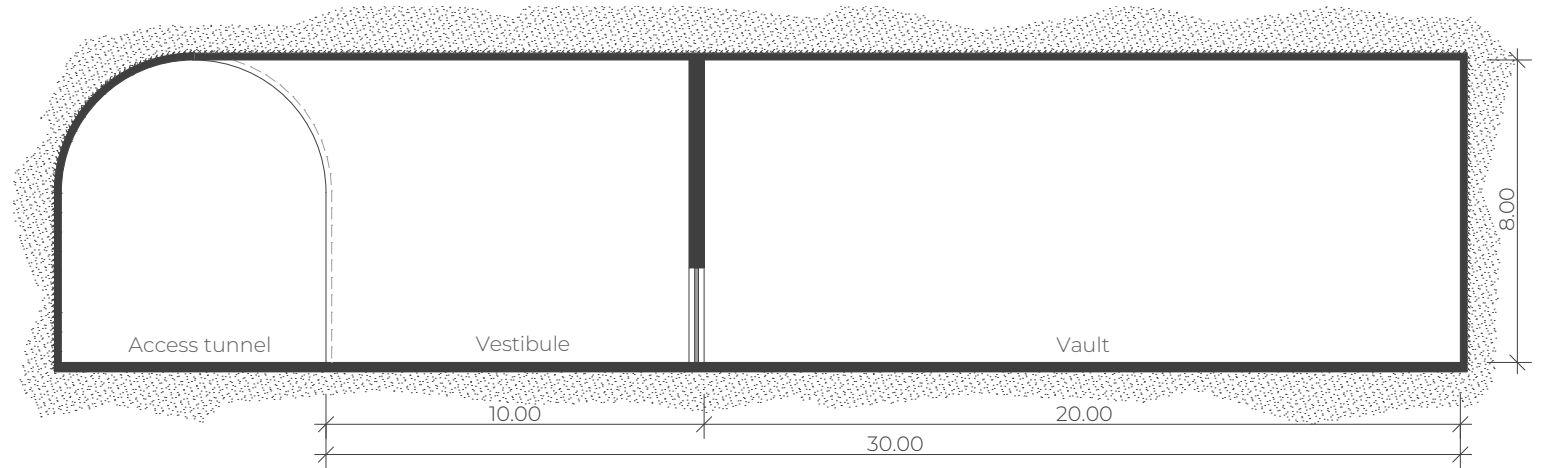

Detail of vault security

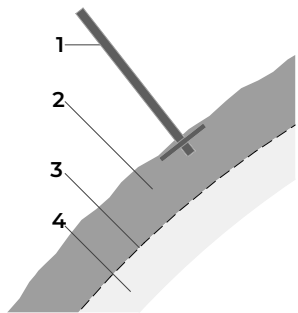

- 1 Rock anchor
- 2 15-20 cm reinforced sprayed concrete (instant protection)
- 3 Sealing
- 4 15-20 cm reinforced sprayed concrete (cladding)

Floor plan

